



## 750 Series Electro-Hydraulic Servovalves

Sapphire Technology



**2-stage mechanical feedback**  
**Low mass, high band-width torque motor**  
**High spool drive forces**  
**Long life "Sapphire Technology" design**  
**High resolution, low hysteresis**  
**Rated flows 95 to 125 l/min at 70 bar**  
**Internal pilot supply (4 port)**  
**ISO 10372 size 4**

Star Hydraulics Limited  
8 Beta Close  
Tewkesbury Business Centre  
Tewkesbury  
Gloucestershire  
GL20 8SR  
England (UK)

## Technical Data

Nominal flow ratings at 70 bar Dp	95 & 125 l/min For other flow ratings consult factory
Hysteresis	< 4.0% without dither
Threshold	< 1.5% without dither
Null shift	
with 40 °C temp change	< 2%
with 70 bar supply pressure change	< 2%
with return pressure 0 to 35 bar	< 2%
Load pressure difference at 1% input	> 60% of supply pressure
Seal material options	FPM, NBR
Temperature range (ambient)	-29 to 135 °C (subject to seal material)
Proof pressure	
at pressure port	150% operating pressure
at return port	100% operating pressure
Burst pressure	250% max supply pressure
External leakage	zero
Degree of protection EN 50529P	IP 65
Weight	1.4 kg
Vibration	30 g, 3 axes
Mounting position	Any, fixed or movable
Supply filtration	
non by-pass	Beta 10 = 200 (10 µm abs)
cleanliness control filter	Beta 3 = 200 (3 µm abs)
Fluid cleanliness level per ISO 4406: 1999	
minimum	16/ 14/ 12
recommended	14/ 12/ 10
Operating pressure (max)	
FPM, NBR	280 bar
Supply pressure	Constant
Fluid viscosity	10 to 100 cSt
Fluid type	Petroleum based mineral oil For operation with other media consult factory

## Technical Data

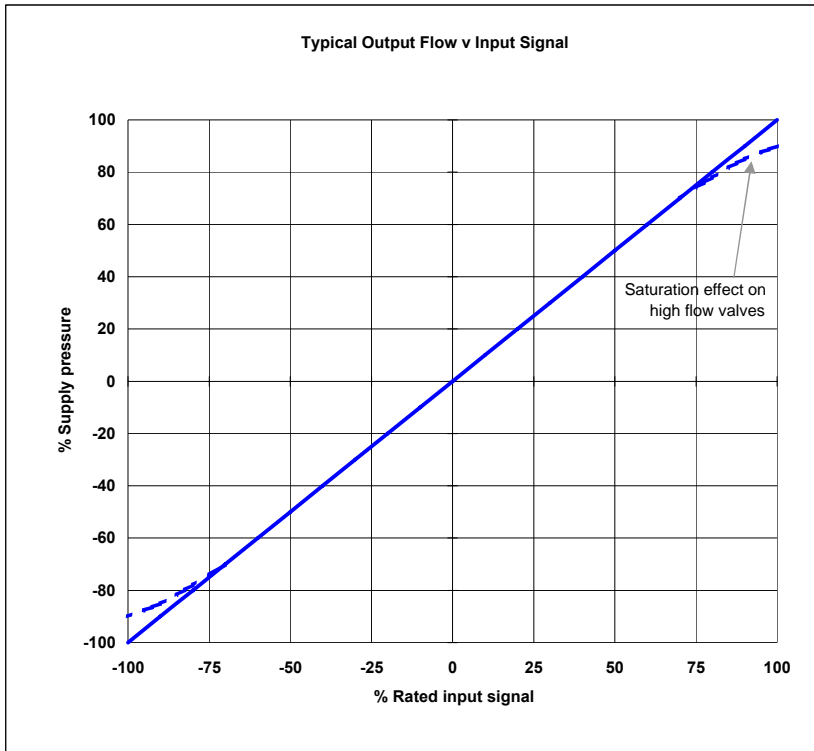

The flow tolerance for standard servovalves is  $\pm 10\%$  of the rated flow at 100% rated input signal.

The rated flow is quoted at 70 bar  $\Delta p$ , 100% rated input signal.

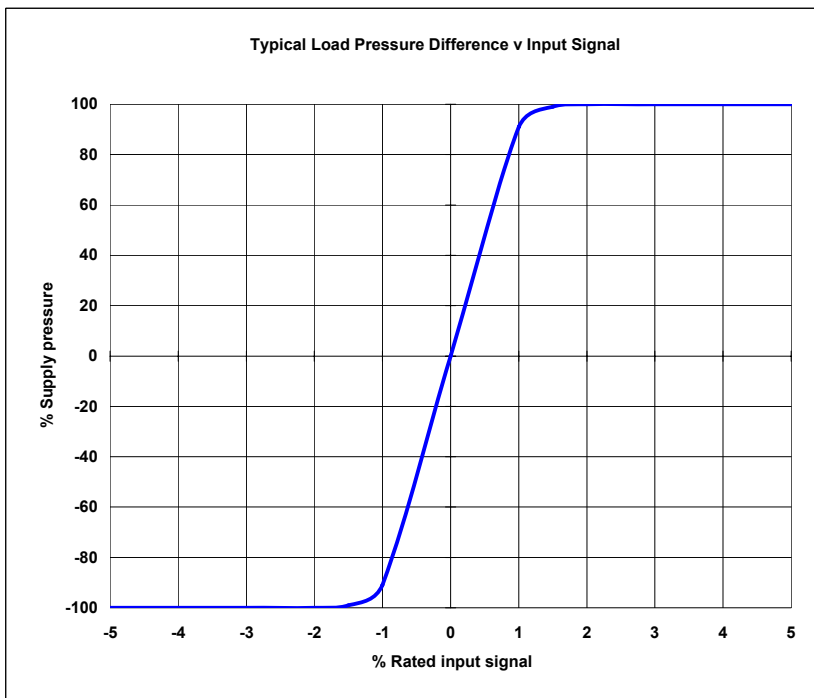

Pressure gain characteristic will vary with positive and negative lap conditions.

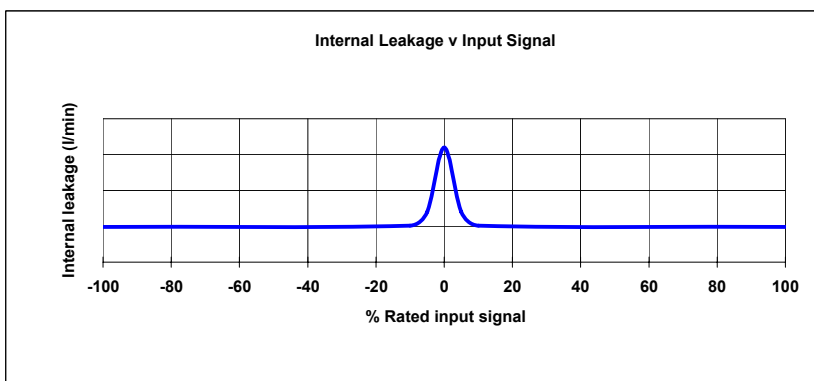

This comprises of both 1st stage flow (tare leakage) and the second stage null leakage.

Figures vary in accordance with rated flow, spool lap and performance characteristics.

## Electrical Details

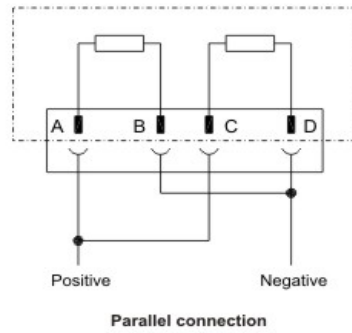
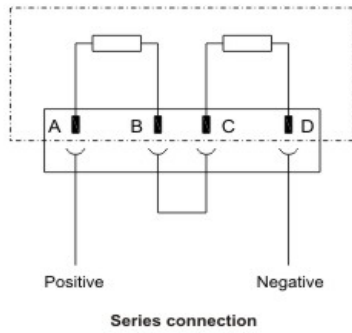

### Output flow polarity

Flow in the direction of P » C2, C1 » R when coils connected as shown

### Coil options

Rated current mA	Resistance / coil Ω	Series connection		Parallel connection	
		Input current mA	Effective resistance Ω	Input current mA	Effective resistance Ω
8	1000	4	2000	8	500
10	1000	5	2000	10	500
15	200	7.5	400	15	100
15	350	7.5	700	15	175
15	600	7.5	1200	15	300
20	1200	10	2400	20	600
30	300	15	600	30	150
30	800	15	1600	30	400
40	80	20	160	40	40
50	80	25	160	50	40
60	40	30	80	60	20
60	320	30	640	60	160
80	22	40	44	80	11
100	27	50	54	100	13.5
200	22	100	44	200	11

### Electrical connector

Standard connector is MS3102E-14S-2P (MIL-5015)

Please contact factory for more options

# Frequency Response

25% In —

100% In —

Rated Flow (l/m) ... 95 & 125

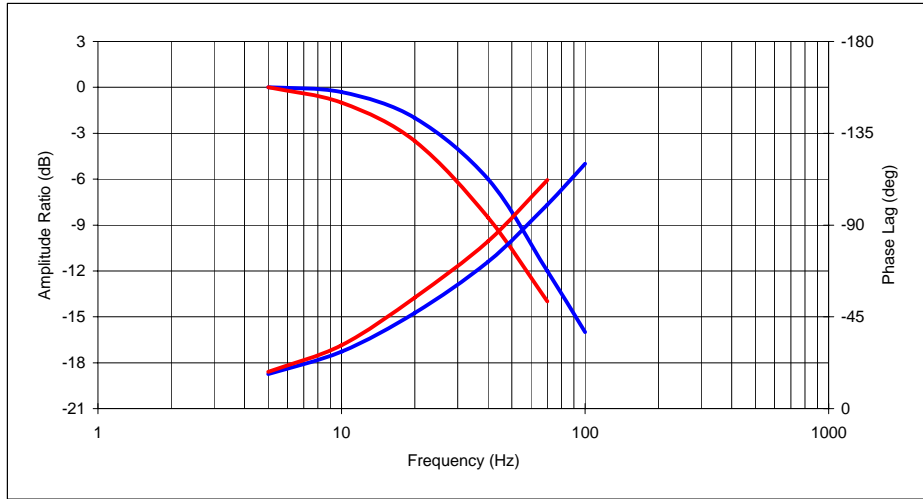

Typical performance curves optimised per 210 bar supply pressure, fluid viscosity 32 cSt at 40 °C

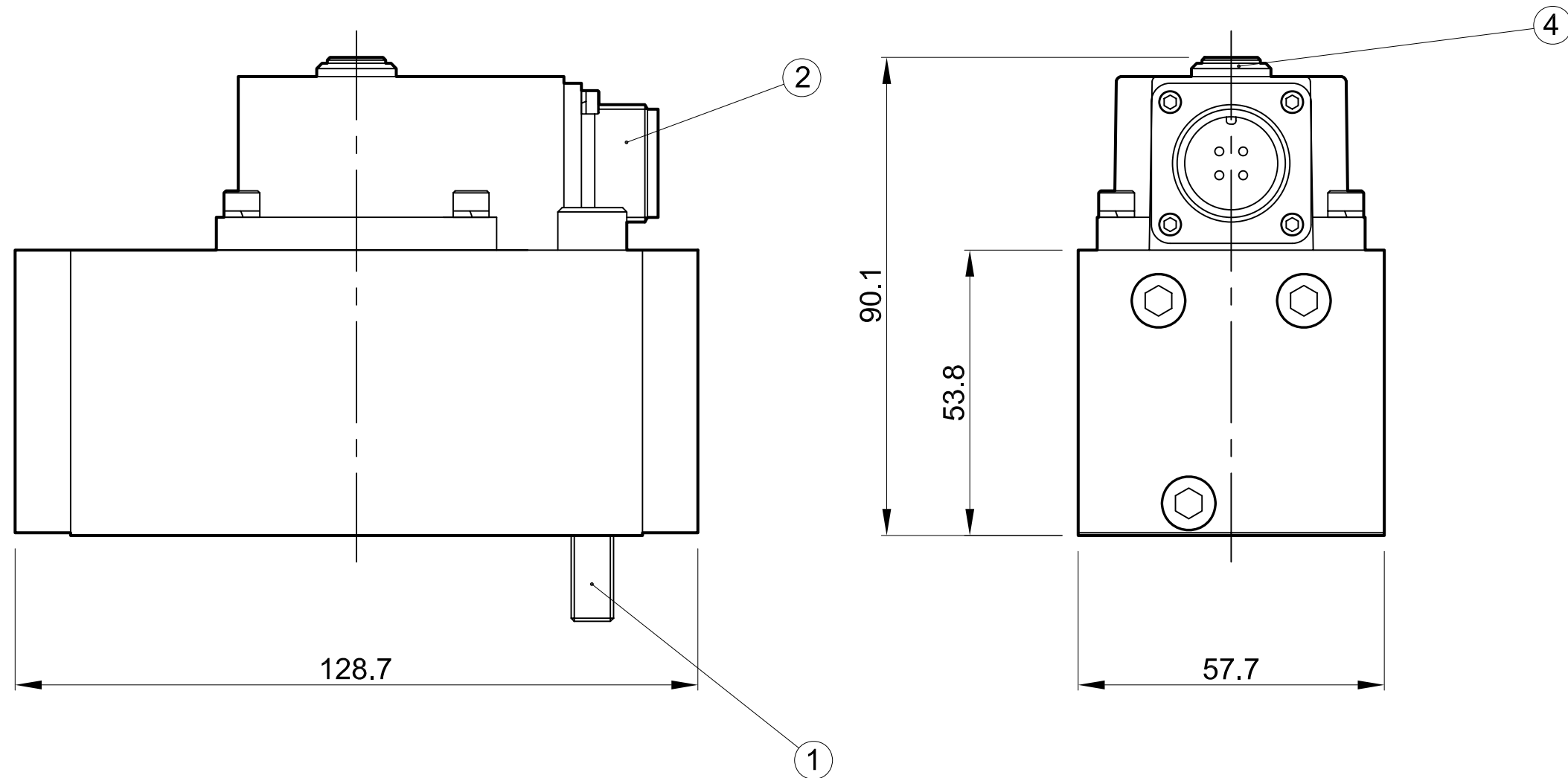

1. Suggested mounting bolts M8 x 70 long high tensile steel socket head cap screws.

2. 4-way electrical connector mates with MS3106-14S-2S or equivalent. Is available at 180° to position shown (advise desired position at time of order).

3. Base O-Rings: 14.60 I/D x 2.40 section (4 pcs).

4. Null adjust requires 2.5 hexagon key. Flow out of C2 will increase with clockwise rotation of key.

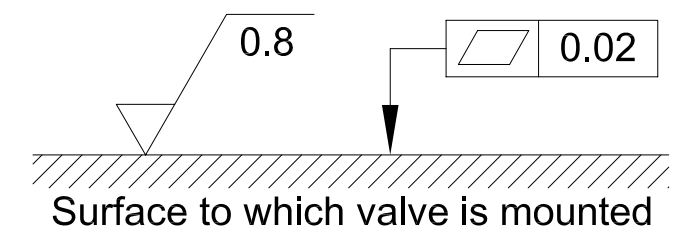
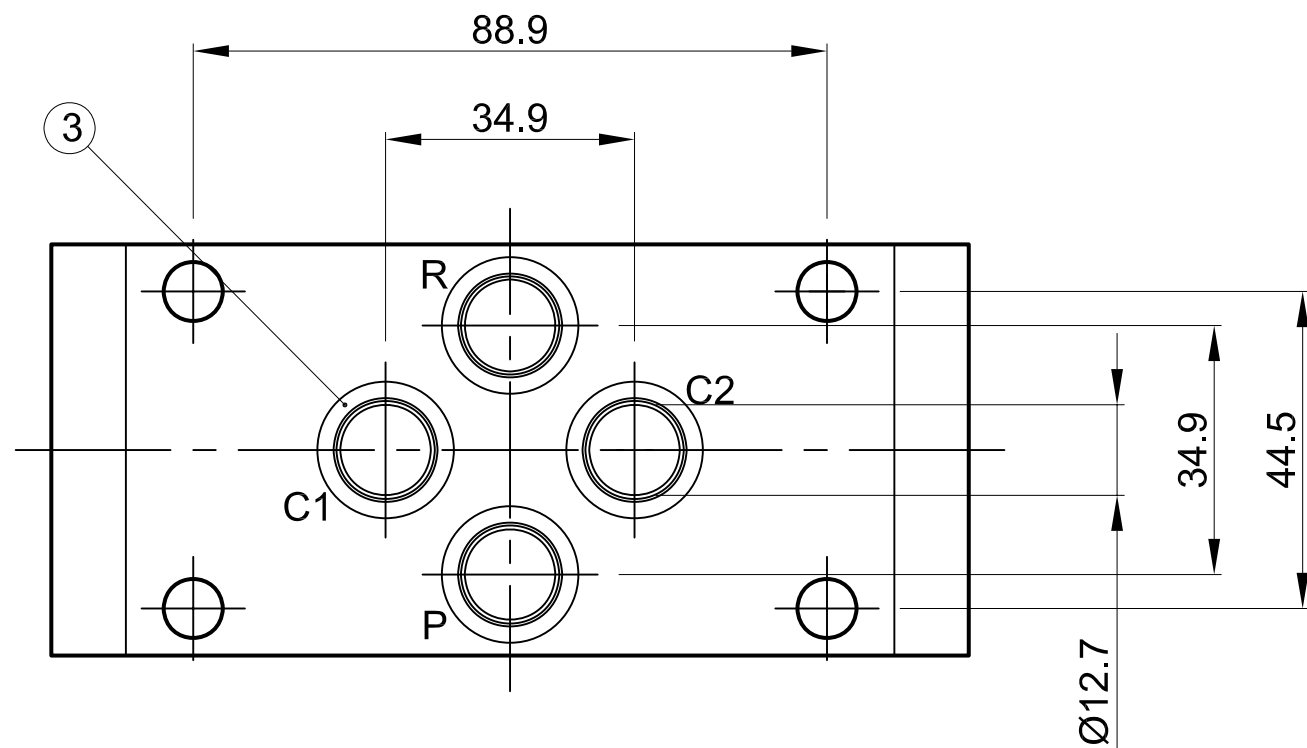

## Installation Details Model 750

Dimensions in millimeters  
3rd angle projection

ID750-2Q10-En

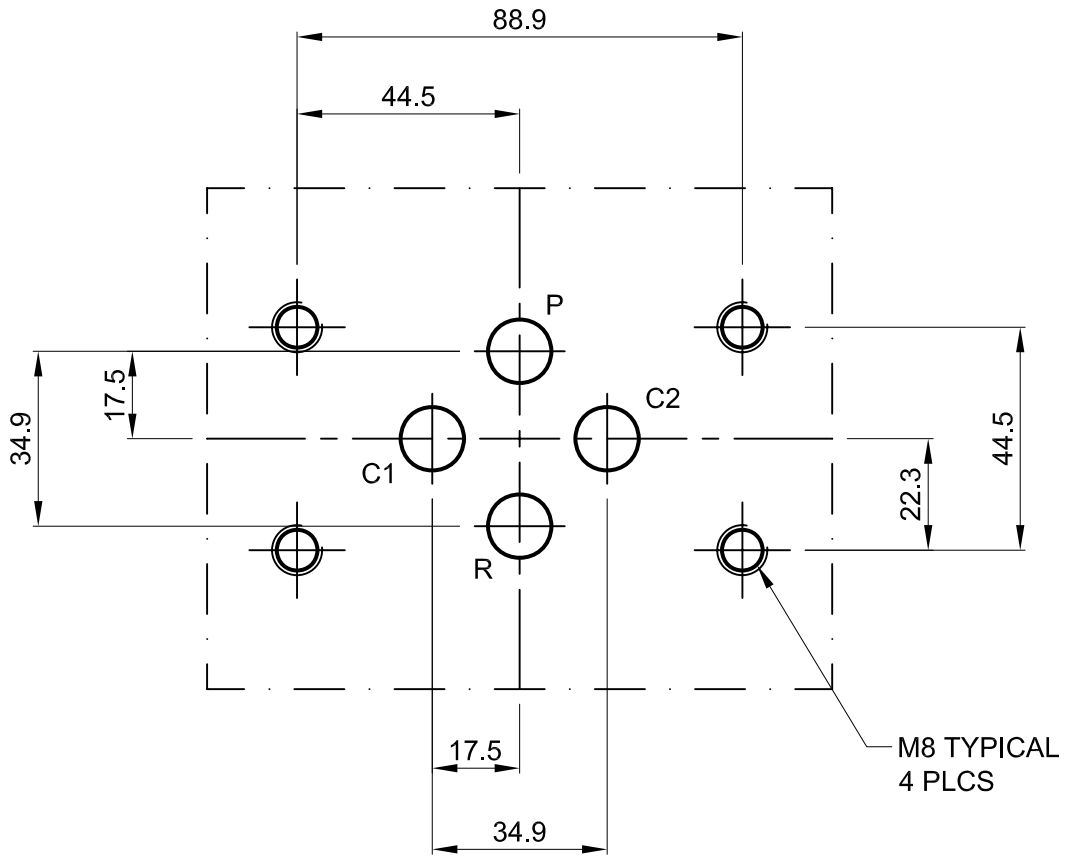

# Manifold Dimensions Model 750

Dimensions in millimeters  
3rd angle projection

Filename

